



SELF-CONTAINED EMERGENCY LED DOWN LIGHT

... is designed with low EMI and specially equipped with a customised proprietary Hybrid IC for higher reliability and greater efficiency in operation. Small and aesthetically in design. Easy installation. Snap in and flush mount firmly onto ceiling/panel. It stays inconspicuously and maintains the original interior decoration of the premises.

Suitable for Banks, Computer Rooms, Offices, Cinemas, Hotels, Shops, Supermarkets, etc.



EHL 136-LED

IP 20



TECHNICAL CHARACTERISTICS

INPUT VOLTAGE	: 230Vac 50/60Hz ± 10% or 115Vac 50/60Hz ± 10% or others
BATTERY	: High temp rated Nickel Cadmium cells 2.4V 2.5Ah / 4.5Ah or others
LAMP USED	: 3W SMT White LED or others
RATED PERIOD	: > 2 hrs, 3 hrs or others
MODE	: Non-maintained
OPERATION TEMPERATURE	: ta 40 °C
POWER CONSUMPTION	: < 3VA
CHARGE/FAULT MONITOR	: Ø 5mm Green LED
RECHARGE PERIOD	: 16 ~ 24 hrs
EMERGENCY LUMINANCE	: 280 lm
ELECTROMAGNETIC FIELD	: 6.9m gauss @ 0.1m
CHARGER	: Hybrid controlled charger
PROTECTION	: Low volt cut-off to prevent battery over discharge Incoming AC fuse, Circuit Protection Fuse and Battery DC fuse Tropical climate protection coating on hybrid control circuit
CONSTRUCTION	: Electrode galvanised sheet steel with epoxy powder coating
DIMENSION	: 373mm(L) x 60mm(W) x 40mm(H)
PACKING	: One unit per carton
CARTON / DIMENSION	: Double wall corrugated / 420mm(L) x 90mm(W) x 90mm(H)
COMPLIANCE	: CP 19-2000, SS263 : Part 2, IEC 598-2-22, AS 2293
WARRANTY	: 1 Year

*HYBRID IC CONTROLLED SELF-CONTAINED EMERGENCY LED DOWN LIGHT
SUPER BRIGHT 3W WHITE LED LAMP LOW POWER CONSUMPTION*

ORDERING INFORMATION

MODEL	LAMP USED	BATTERY CAPACITY	DURATION	GROSS WEIGHT
EHL 136-LED-2ND	3W Super Bright LED	2.5 Ah	2 hrs ± 10%	1.45 kg
EHL 136-LED-4ND	3W Super Bright LED	4.5 Ah	4 hrs ± 10%	1.85 kg

DIMENSION

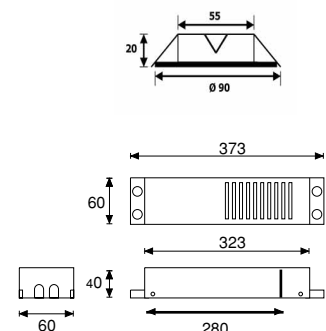

Note: Due to continuous development and improvement, our company reserves the right to change specification without notice.

CERT NO.: SA-0-0200
ISO 9001:2008