

# EL-LED2 LED BULKHEAD

LOW MAINTENANCE EMERGENCY  
BULKHEAD IDEAL FOR BOTH EXTERIOR  
AND INTERIOR AREAS



## TECHNICAL SPECIFICATIONS

MODEL NO:	EL-LED2
Mode of Operation:	Maintained / Non-Maintained
Lamp:	6W White LED
Rated Duration:	3 Hours
Mains Supply:	220-240 Volts, 50-60Hz
Power Consumption:	<1.5W
Battery:	High Temperature Lithium LiFePO4
Charger:	Constant Current/Constant Voltage, Short circuit protected
Charge Monitor:	LED
Test Facility:	Momentary Test Switch
Safety Features:	Low battery voltage cut off to prevent over discharge
Fitting Construction:	Injection moulded with fire retardant (UL94), high impact PC/ABS material
Weight:	Approx. 0.6kg
Dimensions:	120mm (H) x 277mm (W) x 40mm (D)
Standards / Compliance:	SS IEC 60598-2-22, SS 563

\*\*\*Note: Technical Specification subject to change without prior notice

### Ordering Guide:

Ordering Code

EL-LED2NM

### Accessories:

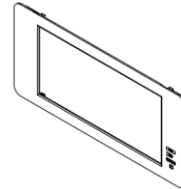

Recess Plate  
EL-LED

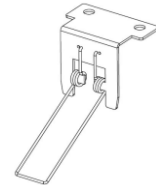

Spring Bracket  
EL-LED

- Low Heat generation, ensures long and reliable service life.
- Low battery voltage cut-off with latch function, to eliminate battery over discharge.
- Charge LED indicator and test switch
- Weatherproof design suitable for indoor and outdoor applications
- Optimal for anti-panic ( open area ) and escape route lighting applications.
- High Quality, Long Life LED module.

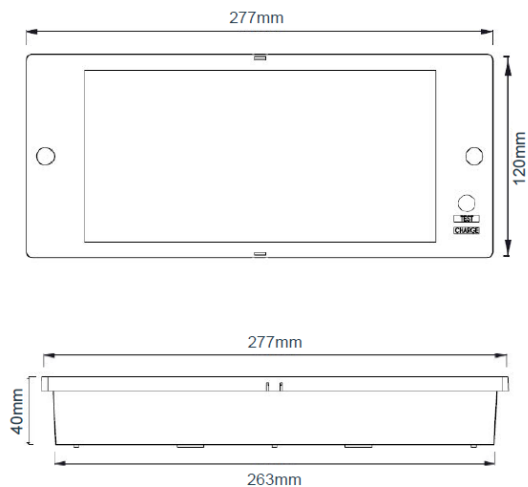

IP65

CLASS II



Type and batch tested with  
PSB PLS-LISTED LABEL